

The National 125 Association of Australia

RULES OF CONSTRUCTION AND MEASUREMENT

Effective June 1, 2010

1. GENERAL

- (a) The 125 Sailing Dinghy is a one design class and the object of these rules is to ensure that boats constructed as to satisfy the requirements of these rules would be entitled to be issued with a 125 Class Certificate of Measurement. The intent of these is to ensure that boats are reasonably uniform in construction and performance potential. The addition of any panel or structure not specifically covered by these rules is not permitted and would constitute evasion of the rules.

Disputations arising from interpretation of the rules or evasion of the rules will be submitted to the State Executive Committee for their decision. In considering their decision, the State Executive will refer the matter to the National Executive Committee.

- (b) These rules are strictly applicable to new boats, kits and plan sets, sails and spars sold after the date these rules became effective. No boat shall be denied a current measurement certificate nor be disqualified from an Association event because of changes in these rules which would otherwise invalidate her entitlement to a certificate.
- (c) A boat must have a valid class certificate of measurement issued before it can be accepted as an entry in State or National Title races. This will not preclude a spot check of any boat to ensure that changes have not occurred which cancel the validity of a certificate.
- (d) Measurement is to be arranged through an official class measurer and payment of the appropriate measurement fee to the Association. A measurement certificate shall be issued following satisfactory measurements and a recommendation from the class measurer concerned.
- (e) Class measurers shall not measure their own boat and if an alternative measurer is not available a senior member of the State Executive Committee is to perform the task.
- (f) If significant changes are made to the boat or rigging (eg. new mast) after a class certificate of measurement has been issued the owner must arrange appropriate re-measuring to maintain the validity of the certificate.
- (g) A certificate of measurement automatically becomes invalid upon change of boat ownership and the new owner is required to arrange re-measurement and pay the appropriate fee for a new certificate.
- (h) In the event of any contrary instruction, these class rules shall overrule any contradiction appearing in any other document.
- (i) The official units of measurement are metric.
- (j) Each hull shall have engraved legibly in the transom or keel the official 125 registration number.
- (k) The radius on the corners of the measured timbers shall not exceed the smaller dimension of the timber.

2. HULL

2.1 BASIC CONSTRUCTION

- (a) The hull shall be constructed of Glass Reinforced Plastic and/or Fibreglass Foam Sandwich construction, Marine or Waterproof type plywood or a combination of any of these materials. Hulls of plywood construction and one-off GRP composite hulls shall be marked out directly from the outline of patterns supplied by the 125 Class Association, which shall be the same as the templates held by the National Measurer. A minor amount of trimming is tolerable to allow for variations inherent in amateur construction, and in the case of GRP one-off boats an allowance should be made to compensate for the difference in thickness between ply and foam, however the completed hull must also be within the dimensions specified in the measurement sheets.
- Should a non-measurement area be considered to have a different shape, then the patterns may be laid over the panel in question. A reasonable fit must be achieved.
- (b) For the purpose of these rules GRP refers to Glass Reinforced Plastic including Fibreglass Sandwich construction.
- (c) The five buoyancy tanks must be capable of being sealed whilst sailing and provision made for removal of water from any tank as a result of accidental water entry.
- (d) To allow 'breathing' a 3mm diameter hole may be drilled as high as possible through each internal bulkhead which separates individual buoyancy tanks.
- (e) Hulls may be sheathed with fibreglass cloth but the use of exotic materials such as kevlar, carbon fibre, boron and the like is prohibited except that these materials may be used in the skin of the centreboard and the rudder.
- (f) The composite hull shall consist of a complete outer GRP hull, other panels may be wood and/or GRP. The parts made of wood to be as the normal timber procedure. Measurements shall be made to GRP structure as per rules applying to GRP, and to the timber structure as per the rules applying to timber.
- (g) The GRP hull shall incorporate foam sandwich construction. Thickness and composition of the laminate is at the discretion of the builder. However non-professional builders are advised to follow the recommended layup in the building instructions. The use of exotic materials in the laminate, such as kevlar, carbon fibre, boron and the like is prohibited.
- (h) If an error or oversight has occurred in the rules, specification or dimensions etc. of the GRP construction the NEC may rectify the problem without recourse to further voting. The intent however must not be reduced or compromised in any way.

2.2 BASIC HULL MEASUREMENT

- (a) Overall length shall be measured along the centreline of the boat from the upper aft face of the transom to the forward extremity of the bow formed by the projection of the side panels.
- (b) Beam measurement shall be measured between the outer edges of the side panels where these are finished flush with the gunwales (sheerline points).
- (c) Bottom panels shall be measured at the transom, main bulkhead and 1500mm from the transom, from the chine to chine around the outside of the vee bottom. The side panels shall be measured at the transom, main bulkhead and 1500mm from the transom (measured around the chine line) from the chine to the edge flush with the gunwales (sheerline point). The measuring point at the chines is to be taken from the intersection of the outside projections of the side and bottom panels in order to overcome difficulty in measuring to rounded corners.
- (d) To check the profile of the keel a base line shall be fixed 225mm below the lowest point of the transom and 50mm below the keel at a point of 3000mm from the aft bottom face of the transom. The distance between the base line and the closest point of the hull shall be within the ~~limits shown on the sketch, i.e. 15mm – 40mm~~ tolerances specified.
- (e) The amount of Vee in the hull bottom (vertical distance from chine to keel) shall be measured at the measurement points in the measurement check sheets and shall be within the minimum and maximum values in the measurement check sheets.
- (f) The amount of convex curvature in the hull bottom panels between the keel and chine shall be measured at the measurement points in the measurement check sheets and shall be no greater than the maximums given in the measurement check sheets.
- (g) The point of maximum convex curvature in the hull bottom panels between the keel and chine shall be no closer than 33% of the individual panel width at each point from either the keel line or the chine.

2.3 WEIGHT

The weight of the hull shall be measured in dry condition with centreboard and all fixed fittings. This excludes rudder assembly, spinnaker or whisker pole, bailing buckets and paddles. Corrector weights, to a maximum of 2kg, shall be bolted to the underside of the thwart.

2.4 CENTREBOARD

- (a) The centreboard shall be of a pivoted type and shall be constructed of timber other than plywood and may be finished with a skin of fibre reinforced plastic, such skin being included in the thickness dimension.
- (b) With the centreboard in the fully lowered position, the distance from the lower extremity to the nearest point of the hull along the slot opening, shall not be greater than 920mm. The distance from the leading edge of the centreboard (where it emerges from the slot) to the transom when measured around the keel curvature, shall be within 1940mm-1980mm.

- (c) The protruding section of the centreboard when fully lowered shall conform to the pattern outline within the tolerance specified. The cross sectional shape may be faired as desired but the thickness of the unfaired portion within the centrecase shall be within 16-21mm.

2.5 RUDDER ASSEMBLY

- (a) The rudder blade shall be made of timber other than plywood. The rudder blade may be finished with a skin of fibre reinforced plastic, such a skin being included in the thickness dimension. The outline profile is optional provided it is less than 280mm in width. With the rudder blade in the fully lowered position, the distance from the lower extremity to the nearest point of the projected hull shall not be greater than 680mm. The cross sectional shape may be faired as desired but the thickness of the unfaired portion within the tiller box shall be within 16-21mm.
- (b) The design of the tiller and the rudder box is optional, but the separation of the pintle/ gudgeon fittings must not be less than 150mm when measured between mounting centres. Pivot and drop dagger blades are permitted. Fixed blades are not permitted. The pivoting point of the pintle/gudgeon fittings shall not exceed a distance of 40mm from the aft face of the transom.
- (c) A means of keeping the rudder captive on the transom fittings in the event of a capsize must be incorporated. Toggle type retainers are not acceptable as the only captive means.
- (d) A tiller extension of optional design is permitted.

2.6 BOW COVER

- (a) The bow cover may be fitted flush with the gunwales or coamings in which case the side panels may be checked out to the thickness of the bow cover. The sides of the bow cover may be trimmed to achieve the fit desired provided that the overlap at least covers the outer edge of the side panels.
- (b) (a) Timber boats - The forward edge of the bow cover shall be finished flush with the forward extremity of the bow formed by the side panels.
- (b) GRP boats - The forward edge of the bow cover shall be rolled over and protrude a maximum of 15mm from the forward extremity of the bow formed by the side panels.
- (c) The length of the bow cover shall be measured along the centreline between the aft and forward edges. A kingplank shall be fitted fore and aft under the centreline of the bow cover on timber boats.
- (d) The depth and profile of the bow cover support shall conform to the pattern over the fitted length, however, if a spinnaker chute is fitted the lower edge of the support may be modified accordingly on either the port or starboard side. The support shall be strong enough to withstand the weight of the boat with the transom the only other point of suspension. In GRP boats, the bow cover support may extend down and join to the foredeck forming the forward termination of the foredeck, in which case the space under the bow cover shall become part of the for-

ward watertight buoyancy compartment and rule 2.6 (e) shall not apply.

- (e) The bow cover may be cut on either the port or starboard side of the kingplank to accommodate a spinnaker chute.

2.7 TRANSOM

- (a) Protrusion of the bottom or side panels past the aft face of the transom is not allowed.
- (b) The transom shall have two drain slots up to the maximum size of 110x30mm and above a minimum size of 90x20mm with the lower edges a maximum of 5mm above the level of the seat tops and positioned athwartships within the limits of the seat top widths.
- (c) The height of the transom shall be within the limits of 310-320mm when measured from the vee bottom point to a line across the top edge of the transom. The top edge of the transom may be straight or curved downwards at the mid point to the maximum of 45mm. Cover straps are included in these dimensions.
- (d) Gussets of approximately triangular shape shall be fitted to strengthen the transom/ gunwale corners. They may be fitted flush with, or proud of, the transom and gunwale top edges. The length of the gussets along the outer edges shall not be less than 75mm.
- (e) The transom stiffener shall not be less than 100x18mm and be fitted the full width of the transom. The depth of the transom stiffener shall be measured from the bottom of any transom curvature.
- (f) The stern post shall not be less than 73x18mm and fitted abutting the keel and lower edge of the transom stiffener.
- (g) The angle at the junction of the transom and the keel shall not be less than 90 degrees.
- (h) Rules (d), (e) and (f) shall not apply to the GRP hull, but reinforcement timber 70x14mm (min.) by full depth of transom shall be built in to replace the sternpost. A knee or brace may be fitted between the transom and keel. The fixing point is not to exceed the internal height of the transom.

2.8 CENTRECASE

- (a) The centre case (centreboard case) profile shall be in accordance with the pattern and the general assembly in accordance with the building instructions.
- (b) The centre case stiffener profile shall conform to the pattern and any holes inserted to facilitate rigging shall not come within 20mm of any edge.
- (c) The distance from the front top edge of the centre case to the aft face of the transom shall be within 2135-2190mm.

2.9 SEAT TOPS

- (a) The width of the seat tops shall be measured at the transom, main bulkhead and at 1500mm from the transom. The height of the seat sides shall be measured at the transom, main bulkhead, and at 1500mm from the transom and be measured from bottom of panel to top of seat top. GRP hulls shall have these measurements taken from the intersection of the

horizontal line of seat top and the line extension of the seat side to allow for radii.

- (b) Inside and outside radii for seat sides, decks, bulkheads and centre case etc. shall comply to the appropriate construction type measurement rule.

2.10 FOREDECK

The foredeck shall not be cut to accommodate a spinnaker chute or other device to receive a spinnaker.

2.11 MAIN BULKHEAD

- (a) The distance of the aft face of the main bulkhead to the aft face of the transom shall be within 2320-2360mm.
- (b) The width at the main bulkhead shall be within 1255-1270mm when measured along the upper aft edge of the foredeck between the side panels. GRP hull main bulkhead width measurement to be 1235-1262mm.
- (c) The height of the main bulkhead measured between the top of the keel and the top of the deck shall be 395-405mm. GRP hull main bulkhead depth to be 400-410mm from floor surface to top of the deck.

2.12 CHAINPLATE PACKING

Chainplate packing reinforcement must be provided to strengthen the area where chainplates are mounted. The packing shall not be less than 100x8mm and also of sufficient length to completely fill the area between gunwale and seat top.

2.13 FLOOR BATTENS

- (a) A minimum of four and a maximum of six floor battens shall be fixed to the inside of the cockpit floor and these may extend past the main bulkhead. The minimum length in the cockpit shall be 1670mm. Section size shall be height 8-15mm and width 30-35mm.
- (b) The floor battens shall be located approximately parallel with the keel.
- (c) No crossribs over the floor battens in the cockpit area shall be allowed except that a plywood and timber gusset, or part thereof, bounded by the thwart, centreboard case side, top of the floor battens and the seat side may be mounted approximately vertically and may be lightened by cutting holes in it.
- (d) Rule 2.13 does not apply to GRP hulls.
- (e) For timber boats older than 5 years, from the issue of the plan set, rule 2.13 may be replaced by the use of foam (of maximum thickness 12mm) sheathed with fibreglass cloth to reinforce the floor.

2.14 GUNWALES & COAMINGS

- (a) Inner and outer gunwales and outer coamings are to be fitted around the full length of the boat but shall not extend beyond the forward edge of the bow cover.
- (b) Inner coamings are to be fitted continuous from the transom and shall exceed a specified minimum of 2230mm when measured around their length from the aft edge of the transom. Inner coaming and gunwale not required in all GRP hull.

- (c) Upper edges of gunwales and coamings are to be flush with each other and the edge of the side panels. The radius of the corners shall not exceed the smallest dimension of the timber.
- (d) The combined measurement of the outer gunwales and coamings, when measured from the outer surface of the topside to the extreme outside edge, shall not exceed 50mm.
- (e) The design of GRP gunwales or coamings shall be optional provided they do not exceed the maximum depth or width measurement specification for timber gunwales.
- (f) Rule 2.14(a) over ridden by rule 2.6(b)(b).

2.15 THWART

The thwart shall be fitted securely to the top of the centrecase and to the seat sides. The sectional dimensions shall not be less than 70x18mm. The thwart position shall be measured from the front top edge of the centre case to the centre of the thwart parallel to centrecase top edging.

2.16 KEEL

The keel shall be continuous and fitted abutting the transom and extending past the front bulkhead. The width of the keel shall be uniform and not less than 73mm between the main bulkhead and transom. Not applicable for GRP.

2.17 SEAT SIDES

The height of seat sides shall be measured at the transom, main bulkhead and at 1500mm from the transom and be measured from bottom panel to top of seat top.

3.0 FITTINGS & EQUIPMENT

3.1 CHAINPLATES

Chainplates may be of single or multi hole type mounted outside the side panels or on the chainplate packing inside the hull. The distance between the centreline of the forward hole and the aft face of the transom measured horizontally shall be 2130-2170mm.

3.2 BOW FITTINGS

The bow fitting shall secure the forestay and jib luff within the forward extremity of the bow formed by the side panels. A temporary frangible extension piece may be attached to the bow to guide the spinaker sheet around the forestay.

3.3 JIB FAIRLEADS

Jib fairleads may be fixed or adjustable on a single track. The point of entry of the jibsheet(s) to the control system shall not allow the clew of the jib to be closer than 350mm to the centreline of the hull. The position of the clew shall be measured by taking a straight line between the bow and the jibsheet(s) control system and measuring along this line to a point 1740mm from the bow. Barber hauler type devices are not allowed.

3.4 BOOM VANG

Boom vang design is optional but must be attached to the mast base or step.

3.5 SELF BAILERS

A maximum of two (2) self bailers are allowed in bottom panels. Location optional.

3.6 INSPECTION HATCHES

Screw and cam type inspection hatches may be fitted in any interior panel including the foredeck.

3.7 DRAIN PLUGS

Watertight drain plugs may be fitted in any panel. These shall not be open whilst the boat is in the water.

3.8 MAINSHEET SYSTEM

Mainsheet system design is optional but if a traveller track is used it shall be attached directly on, and be within the length of, the thwart.

3.9 TRANSOM SCUPPERS

2 only scuppers may be fitted in the transom, material and retaining device is optional, of 150mm maximum length and 100mm maximum height.

3.10 CENTRECASE RUBBERS

Strips of rubber or plastic designed to close off the centrecase slot underwater may be fitted.

3.11 TOE STRAPS

Toe straps may be fitted. Location optional.

3.12 CENTREBOARD CONTROL

Uphaul and downhaul devices for centreboard control are optional. Devices to achieve a gybing board adjustment are not allowed.

3.13 JIB FURLER

The fitting of jib furlers is permitted, but their use whilst racing is not allowed.

3.14 MAST HEAD

An integral cap and sheave or a stand-off sheave for the mainsail halyard may be fitted.

3.15 MAST STEP

Mast step is optional provided that it shall:-

- (a) Be non-adjustable while sailing.
- (b) Prevent any swivelling action.
- (c) Support the end of the mast such that the lower end of the extruded section is not more than 28mm from the true deck level.
- (d) Position the forward face of the mast within 2625mm of the aft face of the transom.
- (e) Aft face of the extruded mast section be no further aft than 15mm forward of the main bulkhead.

3.16 HALYARD LOCK

A mainsail halyard lock may be fitted provided the mainsail can be lowered from the cockpit whilst on the water.

3.17 SPINNAKER RIGGING

The hoist point of the spinnaker shall be measured from the height of the uppermost part of the fixed fitting used to a maximum of 4440mm from the base of the full mast section. The use of cranelike fittings or other special structures, fixed or pivoting, to project the spinnaker hoist point away from the mast are not permitted.

3.18 CUNNINGHAM EYE

A device may be fitted to readily adjust mainsail luff tension whilst sailing.

3.19 CLEW OUTHAUL

A device may be fitted to readily adjust mainsail foot tension whilst sailing.

3.20 JIB LUFF TENSIONER

Jib luff tension may be readily adjusted whilst sailing, but only by a control line from the jib tack corner.

3.21 CONTROL LINE TUBES

The use of tubes through forward buoyancy tanks for the sole purpose of leading rope control lines and rope halyards to the cockpit area are permitted subject to the following limitations:-

- (a) A maximum of four such tubes may be installed.
- (b) The maximum internal diameter of all tubes fitted shall not be greater than 12mm.
- (c) Tubes must be made of either stainless steel, copper or aluminium.
- (d) Each tube must be securely fixed to the hull at each end through a minimum timber thickness of 12mm and must be attached about the middle to the mast understep or block glued to the understep panel.
- (e) Buoyancy tanks must be effectively sealed around tube openings.

- (f) Tubes other than those specifically permitted by this rule are not allowed.
- (g) The requirement for internal fixing necessitates the fitting of inspection hatches or compartments through which tubes pass.
- (h) Fixings shall be in accordance with details shown below:

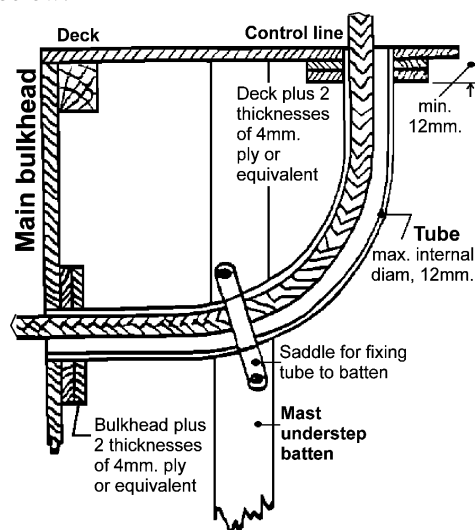

3.22 TOWING FAIRLEAD

A ring or fairlead, constructed of solid stainless steel of minimum thickness 4mm and not less than 38mm internal diameter shall be secured to the bow on the centreline, by which the yacht may be towed or through which a towline may be passed to the thwart.

3.23 NAVIGATIONAL AIDS

The use of 'on board' electronic and or solar powered navigational aids such as Tacktick and GPS systems is NOT permitted. Conventional rotating compasses and time keeping devices are permitted.

Hull Measurement Guide

[timber boat shown]
[all dimensions in millimetres]

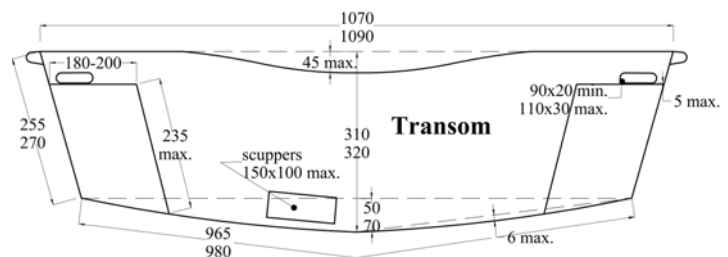
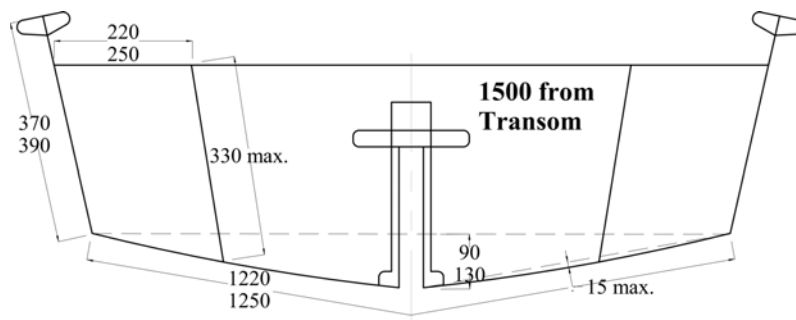
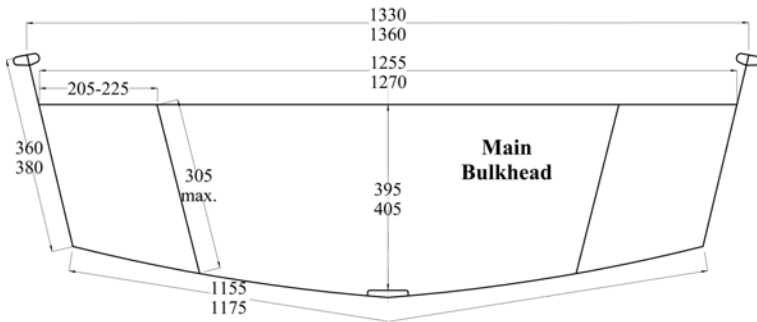
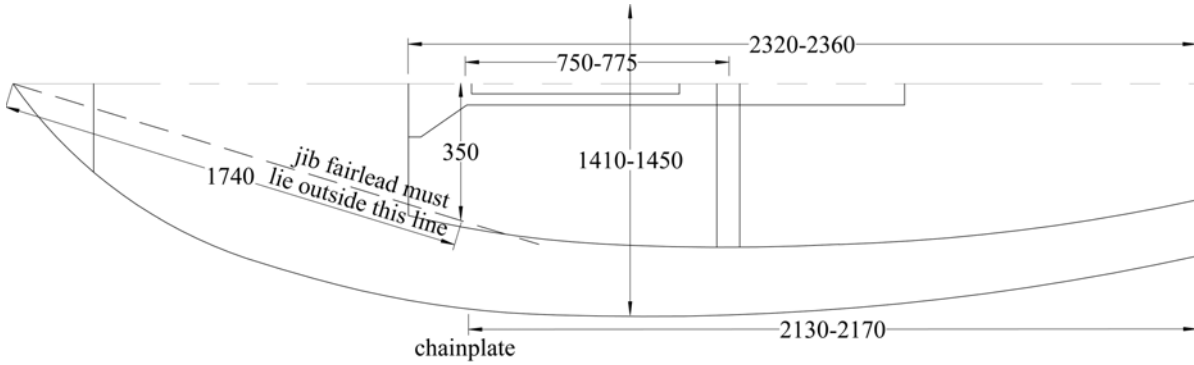
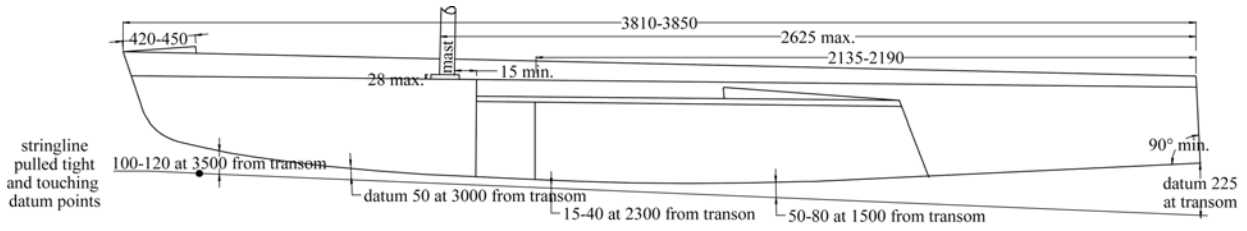

4. SPARS

4.1 MAST - GENERAL

- (a) The mast shall be made from constant section aluminium alloy extrusion (Comalco E 11466, Alcan K4621 or equivalent). Section of the mast shall be within the limits of 65-69mm for the major axis and 49-53mm on the minor axis.
- (b) The length of the mast is 5640-5690mm between the ends of the constant section extrusion. End fittings are not included in the measurements.
- (c) Internal reinforcement specifically intended to reduce bending is allowed.
- (d) The following are not allowed for the mast:-
 - i) Saw cuts to induce bending.
 - ii) Tapering of the section.
 - iii) Permanent bending.
 - iv) Mast preventors.
- (e) Sail limit bands on the mast and boom shall not be less than 20mm wide and shall be permanently painted on. The bands shall be clearly discernable whilst sailing. Bands on the mast shall measure 710mm minimum from the lower end of the extrusion to the inner edge of the band and 5570mm maximum to the inner edge of the upper band. The upper edge of the full boom section shall not be set lower than the upper edge of the band. Whilst racing, the mainsail shall be set within the limit of these bands.
- (f) The mast section shall be sealed against the ingress of water except for a 3mm diameter drain hole in the base.
- (g) Control lines or halyards are not allowed inside the fully enclosed section.
- (h) The height of the jib hound shall be measured from the bottom end of the mast section to the centre of the through bolt.

4.2 MAST RIGGING

- (a) The material and gauge of rigging is optional.
- (b) Support for the mast shall be by one forestay and two sidestays. The forestay may be included as a jib luff. A separate forestay may be used.
- (c) Devices designed to allow adjustment of rig tension of shrouds, jib luff wire, or separate forestay, whilst

sailing are not permitted. Hyfield levers, sliding tracks and turnbuckles of any type are expressly prohibited. Rope lashings are permitted provided they are positioned at the top of the Jib luff wire or separate forestay and tied off before sailing.

- (d) Sidestays, forestay and trapeze wires to be attached to the jib hound position.
- (e) The mast may be fitted with spreader arms. From the base of the extrusion to the centre of the spreader shall be within 1500-2700mm.

4.3 BOOM

- (a) The following are allowed for the boom:-
 - a) Aluminum alloy extrusion to be Comalco section E4778, Alcan K4620 or equivalent. The mast section may be used as an alternate boom section.
 - b) Extrusion length to be within 2120-2130mm.
 - c) Major dimension of section 62-66mm.
 - d) Minor dimension of section 43-47mm.
 - e) Distance from the aft face of the full mast section to the inner edge of band 2070mm maximum.
 - f) Band to be no less than 20mm wide and shall be permanently painted on. The band shall be clearly discernable while sailing.
 - g) Control lines may be fitted inside the boom.
 - h) Small sections of the sail track may be cut away at both ends to accommodate fittings and facilitate sail entry.
- (b) The following are not allowed for the boom:-
 - a) Tapering of the section.
 - b) Saw cuts to induce bending.
 - c) Permanent bending.
- (c) Internal reinforcement specifically intended to reduce bending is allowed.

4.4 SPINNAKER & WHISKER POLES

- (a) The material and fittings used for spinnaker poles and whisker poles are optional. (wood, metal or any fibre reinforced plastic may be used). Poles may be made with sealed ends to ensure they will float.
- (b) The length of the spinnaker pole shall not be greater than the maximum specified when measured between the outer extremities of the pole and fittings.

5. SAILS

5.1 GENERAL

- (a) The sails shall be made from woven sailcloth material and constructed in accordance with these rules, the measurement sheet and the sail plan. The mainsail and jib are to be white with the exception of a panel, positioned in each sail as specified, of a single contrasting colour, the same on both sides. The use of Mylar and Kevlar material or substances of similar mechanical construction in sails is banned. For material to be considered as being woven, when it is torn it shall be possible to separate the fibres without leaving evidence of a film. This must not be confused with filler material.
- (b) The class insignia shall be within the diameter limits specified and conform to the design detailed on the sail plan. It shall be positioned back to back on both sides of the mainsail, above the colour panel, and in the middle of the area bounded by the luff, leech, and both full length battens. The area inside the insignia circle shall be black, with the exception of the double triangular motif, which shall be white.
- (c) Sail numbers of the height specified shall be fixed on both sides of the mainsail and vertically offset so that the upper numbers are on the starboard side; alternatively, numbers which have identical reverse images may be fixed back to back. Numbers shall be positioned below the coloured panel, in the area bounded by the luff, leech, and the upper two short leech battens. The numbers shall be black.
- (d) Measurements shall be taken with sails in a dry state spread on a flat surface and with sufficient tension to remove wrinkles along the line measured. Sails must not exceed the maximum dimensions, whether new or used.
- (e) Bolt ropes shall be included in dimensions or measurement limits and where corner points have been trimmed, measurements shall be taken from the intersection of the continuation of the two edges. [Refer drawings.]
- (f) The Measurer shall identify with waterproof ink each sail which conforms to the rules. Each sail shall be signed and dated by the Measurer on the tack of the mainsail and jib, and the head of spinnaker.
- (g) Reinforcement of any fabric having the effect of stiffening the sail is permitted only within specified limits. Mainsail 295mm from each corner, and at the cunningham eye and termination of batten pockets. Jib 255mm from each corner. Spinnaker 265mm from each corner and at recovery lines. Reinforcement may be carried outside the dimensions shown, but is limited to two layers of the same weight as the body of the sail.

5.2 MAINSAIL

- (a) The mainsail colour panel shall be positioned with the upper edge within 50mm of the lower full length batten pocket and shall be within the specified width limits when measured from corner to corner at the leech.
- (b) The mainsail shall have five batten pockets. The upper two batten pockets shall extend to the luff and the lower three shall be for leech battens. The centreline of the batten pockets shall be within the dimensions specified from the head, in the line of leech measurement.
- (c) The ends of the batten pockets shall follow a fair curve around the leech from the headboard to the clew. The leech may contain a leech line adjustment cord.
- (d) A loose footed mainsail is not allowed.
- (e) The head of the mainsail shall be no larger than the template specified in the sail plan.
- (f) The leech measurement shall be taken in a straight line from the head corner (at the luff) to the clew corner.
- (g) The cross measurement shall be the distance from the leech measurement points, as defined below, to the nearest points on the foreedge of the sail including the bolt rope. The points on the leech from which the cross measurements are taken shall be determined bridging any hollows in the leech with straight lines. The mid-point of the leech shall be determined by folding the head to the clew and the quarter and three-quarter leech points by folding the clew and the head to the midpoint of the leech.
- (h) Leech batten pockets shall be measured from the maximum inside dimension, ignoring the affect of any elastic or other retaining device. The length shall be measured from stitching to stitching.
- (i) A mainsail window is permitted. The total area of the transparent material shall not exceed an area of 0.13m². The top side of the window shall be no higher than the $\frac{1}{4}$ height measurement on the leech, which is projected parallel to the foot of the sail. Tell tale windows are not permitted.
- (j) A cunningham eye, cringle or sheave may be fitted.

Sail Measurement Guide
 [all dimensions in millimetres]

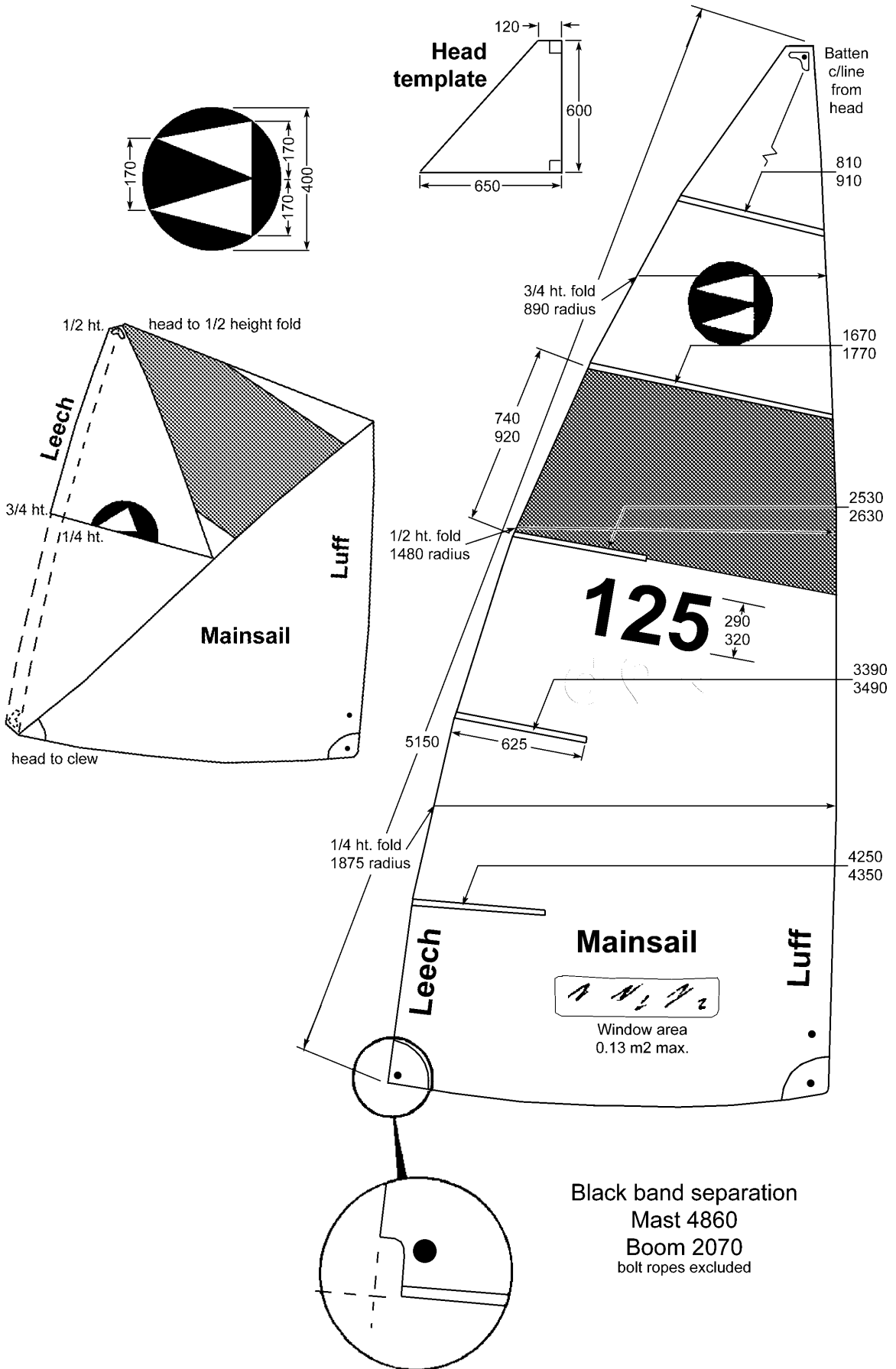

5.3 JIB

- (a) The jib colour panel shall be within the specified width limits when measured along the leech. The upper edge of the colour panel shall be positioned within the limits specified when measured along the leech from the jib peak. Note rule 5.1(e).
- (b) The jib luff may incorporate the forestay wire.
- (c) The leech may be straight or concave but not convex. Battens are not allowed.
- (d) A clear panel (window) up to the maximum of 0.13m^2 may be fitted in the jib and shall not be closer to the luff, leech or foot than 150mm.
- (e) The luff measurement shall be made with the luff in a straight line.
- (f) Foot and leech measurements shall be taken in a straight line (chord measurements) disregarding any foot or leech curvature.
- (g) The mid-point of the foot shall be determined by placing the tack over the clew, such that the extension of the luff, leech and foot coincide, and tensioning both halves of the foot equally.

Curvature of the foot shall be symmetrical about the centre and shall not exceed 15mm maximum difference between halves when folded. The length of the centre measurement shall be taken as the distance between the extension of the luff and leech and the lowest edge of the sail at the mid-point of the foot. For the purpose of taking the centre measurement there shall be no tension on the luff, leech or foot.

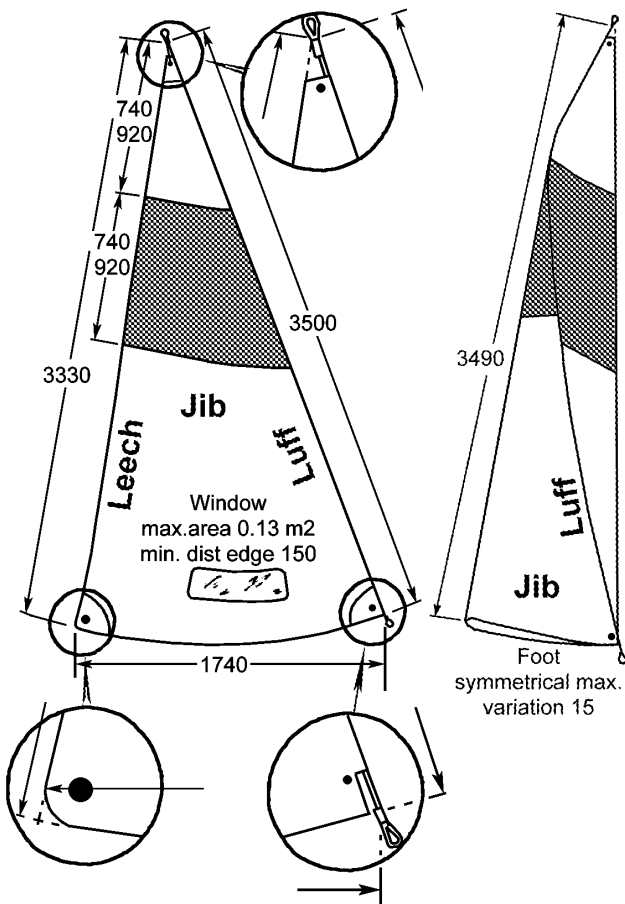

5.4 SPINNAKER

- (a) The spinnaker shall be symmetrical about the centreline and may be of any colour or combination of colours.
- (b) Luff, half foot and centre fold measurements shall be taken around the perimeters with the spinnaker folded so that the luffs and clews are brought together and the material smoothed out to the centre fold thus formed.
- (c) The width along the half height fold shall be measured with the peak further folded to the clews maintaining the luffs coincident and smoothing out the material to the half height fold thus formed. Centrefold length may be measured by holding up the sail and laying the tape measure in the sail's centreline.
- (d) No headboard, batten, or other stiffening device other than normal woven cloth reinforcement is permitted in the spinnaker.

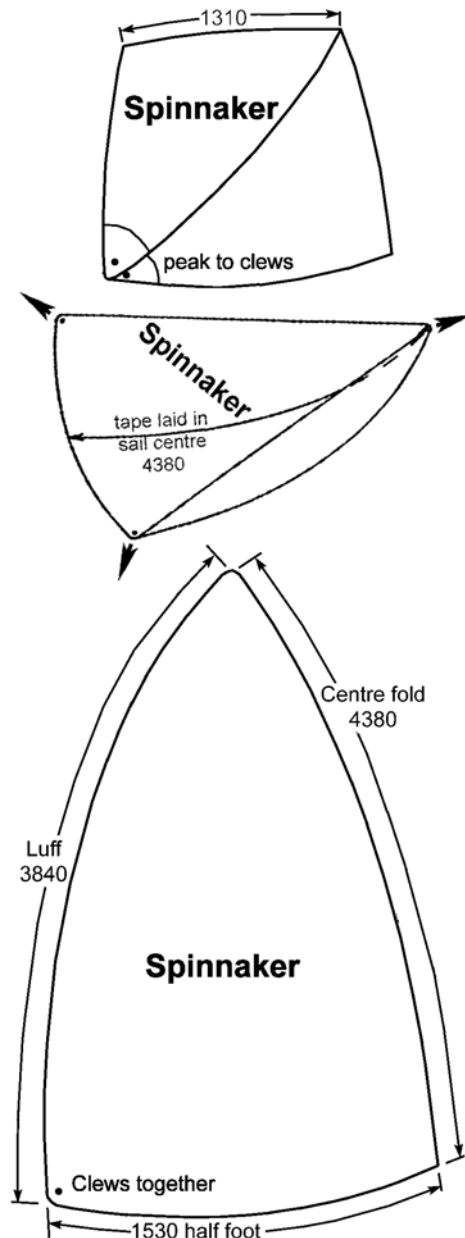

National 125 Association of Australia

Measurement and Check Sheets

Meas. No.	Rule No.	Requirement	Min. mm.	Actual mm.	Max. mm.
HULL					
1a	2.1a	Plywood	4		5
1b	1.0j	Registration no. engraved keel/transom	-	Yes/No	-
1c	1.0	Timber radii OK.	-	Yes/No	-
2	2.1c	5 Buoyancy tanks: sealed & water removal OK	-	Yes/No	-
3	2.2a	Overall length	3810		3850
4	2.2b	Beam: at main bulkhead	1330		1360
5	2.2b	at maximum point	1410		1450
6	2.2b	at transom	1070		1090
7a	2.2c	Chine to sheerline: at main bulkhead	360		380
7b	2.2c	1500mm from transom	370		390
8	2.2c	at transom	255		270
9a	2.2c	Chine to chine: at main bulkhead	1155		1175
9b	2.2c	1500mm from transom	1220		1250
10a	2.2c	at transom	965		980
10b	2.2d	<u>Keel to base line:</u> <u>1500 from transom</u>	<u>50</u>		<u>80</u>
10c	2.2d	<u>2300 from transom</u>	<u>15</u>		<u>40</u>
10d	2.2d	<u>3500 from transom</u>	<u>100</u>		<u>120</u>
10e	2.2e	<u>Chine to keel (vertical): at transom</u>	<u>50</u>		<u>70</u>
10f	2.2e	<u>1500 from transom</u>	<u>90</u>		<u>130</u>
10g	2.2f	<u>Convex curvature: at transom</u>	-		<u>6</u>
10h	2.2f	<u>1500 from transom</u>	-		<u>15</u>
11	2.3	Weight of dry hull	50Kg		-
12	2.4a	Centreboard: solid timber	-	Yes/No	-
13	2.4b	extension below hull	-		920
14	2.4b	for'd edge to transom	1940		1980
15	2.4c	conforms to pattern	-5	Yes/No	+5
16	2.4c	thickness within centre case	16		21
17	2.5a	Rudder blade: solid timber	-	Yes/No	-
18	2.5a	width	-		280
19a	2.5a	thickness within rudder box	16		21
19b	2.5a	extension below hull	-		680
20a	2.5b	Rudder box: pintle/gudgeon centres	150		-
20b	2.5b	rudder pivoting point to transom	-		40
21	2.5c	captive device complies	-	Yes/No	-
22	2.6a	Bow cover: overlaps side panels	-	Yes/No	-
23a	2.6a	forward edge flush	-	Yes/No	-
23b	2.6b	king plank fitted	-	Yes/No	-
24	2.6b	length	420		450
25	2.6d	Bow cover support: profile conforms	-	Yes/No	-
26	2.6d	strength OK	-	Yes/No	-

Measurer's comments:

National 125 Association of Australia Measurement and Check Sheets

Meas. No.	Rule No.	Requirement	Min. mm.	Actual mm.	Max. mm.
27	2.7a	Transom: flush with ends of panels	-	Yes/No	-
28a	2.7b	2 drain slots located OK	-	Yes/No	-
28b	2.7b	drain slot size	90x20		110x30
28c	3.9	scuppers max. 2	-		150x100
30	2.7c	height	310		320
31	2.7d	outer edges of gussets	75		-
32	2.7e	stiffener fitted full width	-	Yes/No	-
33	2.7e	stiffener section	100x18		-
34	2.7c	depth of any curvature	-		45
35a	2.7f	stern post section	73x18		-
35b	2.7g	angle transom to keel 90° or more	-	Yes/No	-
36	2.8a	Centre case: conforms to pattern	-	Yes/No	-
37	2.8c	front top edge to transom	2135		2190
38	2.8b	Centre case stiffener: profile conforms	-	Yes/No	-
39	2.8b	edge to holes	20		-
40a	2.9a	Seat top width: at main bulkhead	205		225
		GRP	201		221
40b	2.9a	at 1500mm from transom	220		250
		GRP	216		246
40c	2.9a	at transom	180		200
		GRP	176		196
41	2.11a	Main bulkhead: to transom	2320		2360
42	2.11b	width between panels	1255		1270
		GRP	1235		1262
43	2.11c	Depth	395		405
		GRP	400		410
44	2.12	Chainplate packing: length x thickness	100x8		-
45	2.12	fills space	-	Yes/No	-
46a	2.13	Floor battens: height	8		15
46b	2.13	width	30		35
47	2.13	4 or 6 fitted	-	Yes/No	-
48a	2.13	length in cockpit	1670		-
48b	2.13c	reinforcement gusset complies	-	Yes/No	-
49	2.14a	Inner & outer gunwales and outer coamings fitted full length and termination at bow OK	-	Yes/No	-
		GRP max. overhang	-		15
50	2.14b	Inner coaming length	2230		-
51	2.14c	Gunwales section: inner & outer	30x12		-
52	2.14c	Coamings section: inner & outer	23x11		-
53	2.14d	Combined measurement outer gunwales & coamings	-		50
54a	2.15	Thwart sectional dimensions	70x18		-
54b	2.15	Thwart centre to top front edge of centre case	750		775
55	2.16	Keel: uniform width	73		-
56a	2.17	Seat sides height: at main bulkhead	-		305
		GRP	-		300
56b	2.17	at 1500mm from transom	-		330
		GRP	-		320
56c	2.17	at transom	-		235
		GRP	-		230

Measurer's comments:

National 125 Association of Australia

Measurement and Check Sheets

Meas. No.	Rule No.	Requirement	Min. mm.	Actual mm.	Max. mm.
FITTINGS & EQUIPMENT					
61	3.1	Chainplates: for'd hole to transom	2130		2170
62	3.2	Bow fitting: forestay luff location OK	-	Yes/No	-
63	3.8	Mainsheet track/hawse on thwart	-	Yes/No	-
64	3.15a	Mast step: fixed whilst sailing	-	Yes/No	-
65	3.15b	prevents swivelling	-	Yes/No	-
66	3.15c	mast end above true deck level	-		28
67	3.15d	front of mast to transom	-		2625
67a	3.15e	aft face of mast to main bulkhead	15		-
68	3.16	Mainsail can be lowered from cockpit	-	Yes/No	-
69	3.21	Tubes: number installed	-		4
70	3.21	installed by approved method	-	Yes/No	-
71	3.21	internal diameter	-		12
72	3.4	Boom vang to mast, mast base or step	-	Yes/No	-
73	3.5	Number of venturi self bailers fitted	-		2
74	3.3	Jib clew to centreline of hull – 1740 from bow	350		-
MAST					
76	4.1b	Mast: length	5640		5690
77	4.1a	major axis	65		69
78	4.1e	minor axis	49		53
79	4.1e	width of painted bands	20		-
80	4.1e	height of upper band (lower edge)	-		5570
81	4.1e	height of lower band (upper edge)	710		-
83	3.17	height of spinnaker hoist point	-		4440
84	4.1b	height of jib hound bolt	3850		3870
85	4.1f	sealed OK	-	Yes/No	-
86	4.1f	drain hole or foam filled	-	Yes/No	-
87	4.2d	Two sidestays to jib hound	-	Yes/No	-
88	4.2d	Forestay to jib hound	-	Yes/No	-
89	4.2d	Trapeze wires to jib hound	-	Yes/No	-
91	4.2e	Location of spreader arms	1500		2700
BOOM					
97	4.3a	Boom major axis [or mast section as alternate]	62		66
98	4.3a	Minor axis [or mast section as alternate]	43		47
99	4.3a	Length	2120		2130
100	4.3a	Width of painted bands	20		-
101	4.3a	Location of painted band	-		2070
SPINNAKER & WHISKER POLES					
107	4.4b	Spinnaker pole overall length	-		2260

Measurer's comments:

National 125 Association of Australia

Measurement and Check Sheets

Meas. No.	Rule No.	Requirement	Min. mm.	Actual mm.	Max. mm.
SAILS – GENERAL					
111	5.1a	Sails white with coloured panels	-	Yes/No	-
112	5.1b	Class insignia: location OK	-	Yes/No	-
113	5.1b	diameter	385		415
114	5.1c	Sail numbers: positioned OK	-	Yes/No	-
115	5.1c	height	290		320
116	5.1g	Reinforcement OK	-	Yes/No	
MAINSAIL					
119	5.2a	Colour panel: positioned OK	-	Yes/No	-
120	5.2a	width along leech	740		920
121	5.2b	Centreline batten pocket to head: #1	810		910
		#2	1670		1770
		#3	2530		2630
		#4	3390		3490
		#5	4250		4350
122	5.2h	Length of leech batten pockets	-		625
123	5.2c	Leech: edge curved fair	-	Yes/No	-
124	5.2e	Head fits template	-	Yes/No	-
126	5.2f	Leech measurement	-		5150
127	5.2g	Cross measurement: ½ height	-		1480
128	5.2g	¾ height	-		890
129	5.2g	¼ height	-		1875
130	5.2i	Mainsail window: area	-		0.13m ²
131	5.2i	location OK	-	Yes/No	-
JIB					
133	5.3a	Colour panel: width along leech	740		920
134	5.3a	upper corner to peak	740		920
135	5.3d	Jib window area	-		0.13m ²
136	5.3e	Luff measurement	-		3500
137	5.3f	Foot measurement	-		1740
138	5.3f	Leech measurement	-		3330
139	5.3g	Centre measurement	-		3490
140	5.3g	Foot curvature symmetrical	-		15
141	5.3d	Jib window located OK	-	Yes/No	-
SPINNAKER					
143	5.4a	Symmetrical about centreline	-	Yes/No	-
144	5.4b	Luff perimeter	-		3840
145	5.4b	Half foot perimeter	-		1530
146	5.4b	Centre fold perimeter	-		4380
147	5.4c	½ height fold width	-		1310

Measurer's comments: